

SPECIFICATIONS



Full Turn/1/2" NPT/SWEAT

Features

- Full Turn
- 1/2" Male Threaded Connection
- Chrome Plated
- With Spring Loaded Stop Mechanism
- Working/Maximum Water Pressure: 125 psi
- Working Water temperature: 32°F~140°F (0°C~60°C)
- Maximum Water Temperature: 180°F (82°C)
- Warranty – Limited 1 Year
- Replaceable Stem and Vacuum Breaker

MODEL	DIMENSIONS				PACK QTY	
	SIZE	A	B	C	INNER BOX	MASTER BOX
MLFF12M-8	8 INCH	13.03	3.11	7.87	10/BOX	20/BOX
MLFF12M-10	10 INCH	15.11	3.11	9.96	10/BOX	20/BOX
MLFF12M-12	12 INCH	17.21	3.11	12.04	10/BOX	20/BOX
MLFF12M-14	14 INCH	19.29	3.11	14.13	10/BOX	20/BOX

Drawings

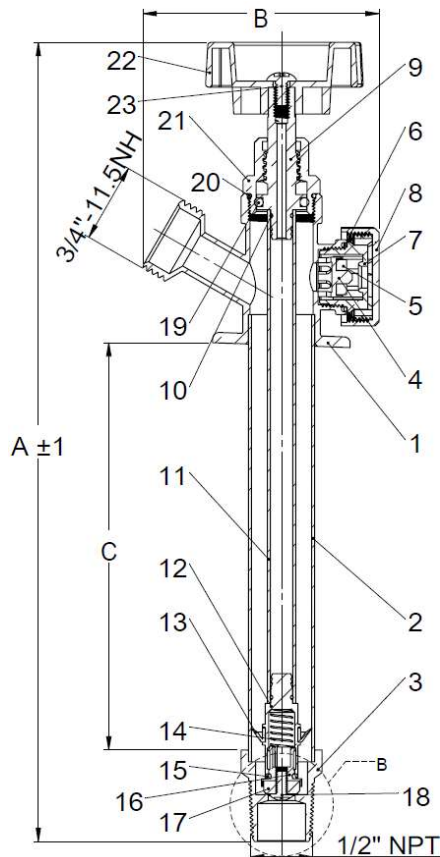

Parts*

NO	PART	MATERIAL
1	VALVE BODY	BRASS
2	BODY OUTSIDE TUBE	BRASS
3	END ADAPTER 1/2" MALE	BRASS
4	VACUUM BREAKER PISTON	POM
5	VACUUM BREAKER SEAT WASHER	NBR
6	VACUUM BREAKER O-RING	NBR
7	VACUUM BREAKER BODY	POM
8	VACUUM BREAKER CAP	ABS
9	VALVE OPERATION STEM	BRASS
10	O-RING	NBR
11	INSIDE STEM TUBE	BRASS
12	STEM GUIDE	BRASS
13	O-RING	NBR
14	SPRING	SS
15	O-RING	NBR
16	PISTON CHECK	BRASS
17	SEAT WASHER	NBR
18	SEAT WASHER SCREW	SS
19	STEM OPERATION O-RING	NBR
20	O-RING	NBR
21	BODY PACKING NUT	BRASS
22	HANDLE	ABS
23	HANDLE SCREW	SS

- Parts List provided for reference purpose. Available Replacement Parts Below:

- **MLFFSVBK** – Vacuum Breaker
- **MLFFSTEM** – Full Turn Faucet Replacement Stem

Service & Parts

Please reach out to epleservice@emcoltd.com for support/ visit mainlinecollection.ca / CANADA +1 (450) 621 5636