

Installation / Installation / Instalación

Tremé

Pull-down Kitchen Faucet

Robinet de cuisine à bec arroseur
Grifo extraíble de cocina



Tools You Will Need / Outils dont vous aurez besoin / Herramientas necesarias



Adjustable Wrench

Clé à molette

Llave ajustable



Hex Wrench

Clé hexagonale

Llave hexagonal



Phillips Screwdriver

Tournevis cruciforme

Destornillador Phillips



Silicone Sealant

Enduit d'étanchéité au silicone

Sellador de silicona

INSTALLATION TIPS

- The manufacturer suggests using a locally licensed plumber for installation.
- Cover your drain to avoid losing parts.

CONSIGNES DE INSTALLATION

- Le fabricant suggère de confier l'installation à un plombier qualifié pour exercer dans cette région.
- Couvrir le drain pour ne pas perdre des pièces.

CONSEJOS DE INSTALACIÓN

- El fabricante sugiere usar los servicios de un plomero local autorizado para la instalación.
- Tape la boca del desagüe para prevenir la pérdida de piezas pequeñas.



Installation / Installation / Instalación

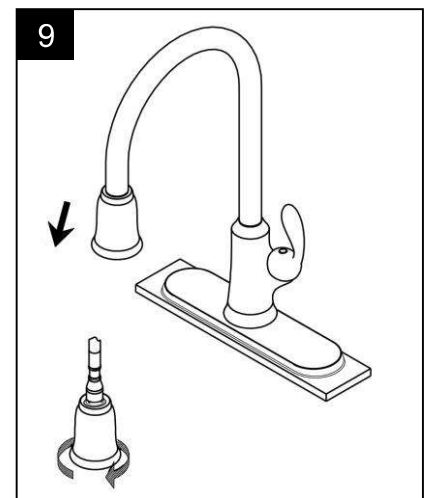
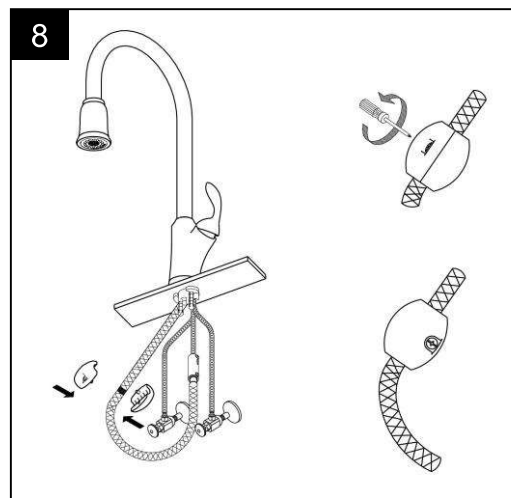
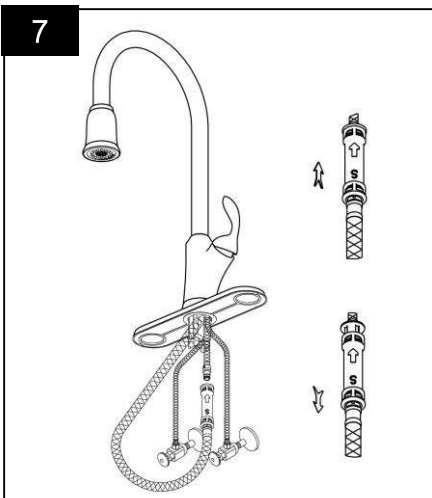
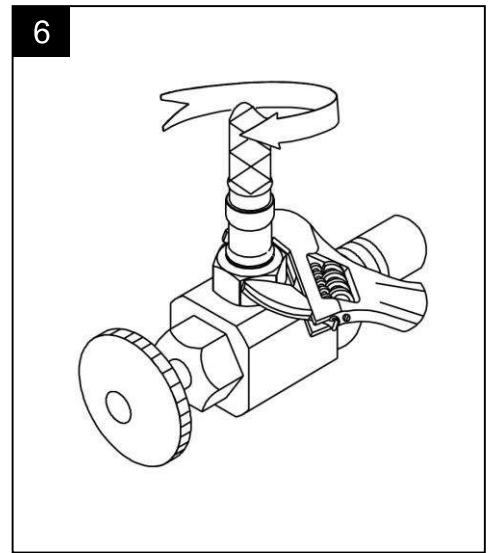
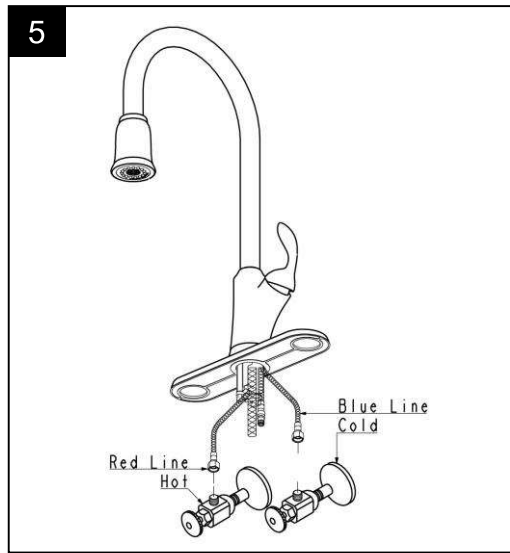
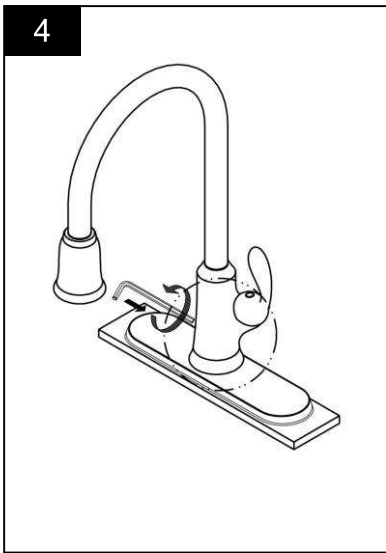
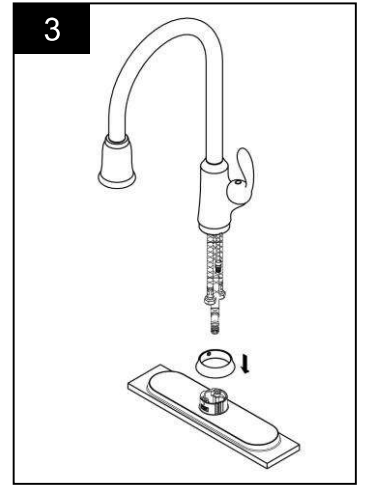
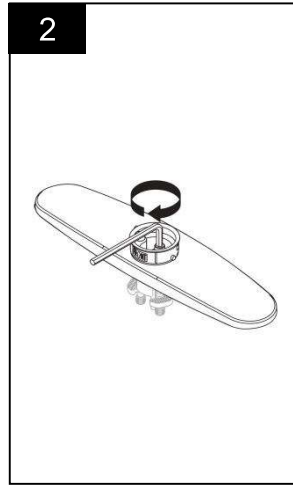
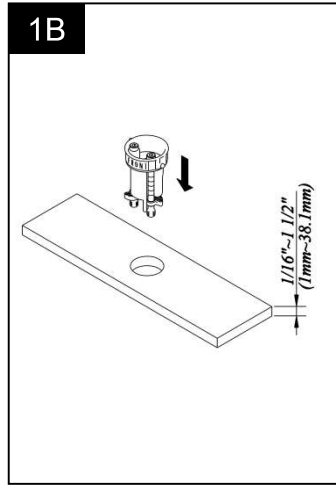
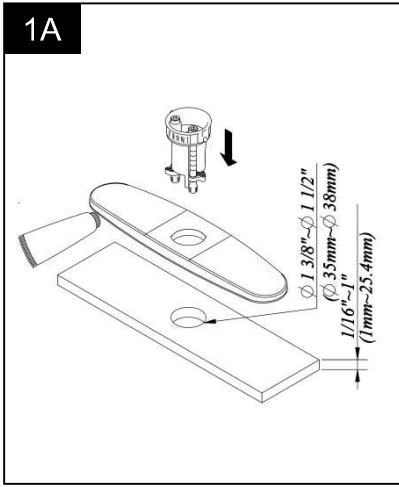

Installation / Installation / Instalación

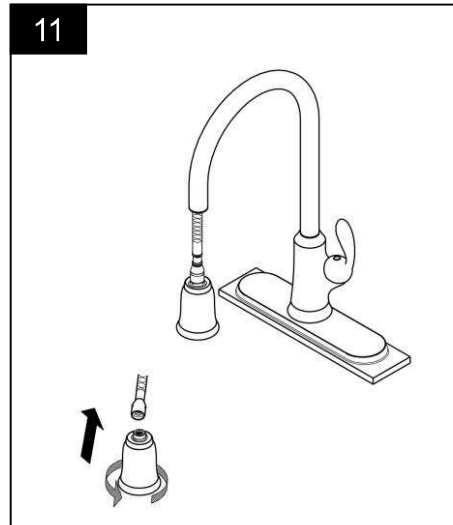
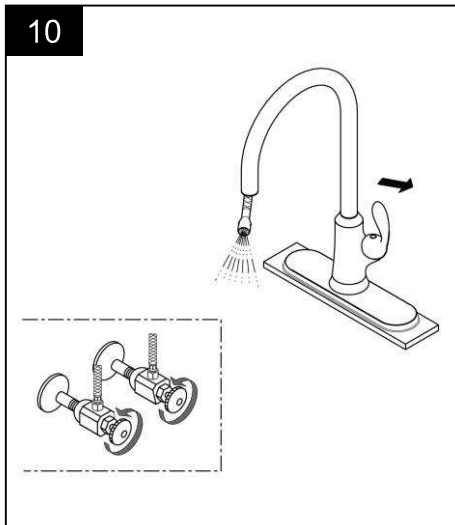

Troubleshooting / Dépannage / Guía de solucionar problemas

If you've followed the instructions carefully and your faucet still does not work properly, take these corrective steps.

Si vous avez suivi attentivement les instructions et que votre robinet ne fonctionne toujours pas correctement, apporter les correctifs suivants.

Si usted ha seguido las instrucciones cuidadosamente y su grifo todavía no funciona correctamente, siga estos pasos correctivos.

Problem / Problème / Problema	Cause / Cause / Causa	Action / Correctif / Solución
Leaks underneath handle.	Retainer nut has come loose. O-ring is dirty or damaged.	Tighten the retainer nut. Clean or replace O-ring.
Fuites sous la poignée.	L'écrou de fixation s'est desserré. Le joint torique est sale ou endommagé.	Serrer l'écrou de fixation. Nettoyer ou remplacer le joint torique.
Goteo debajo de la manija.	La tuerca de ajuste se ha aflojado. La arandela circular está sucia o dañada.	Apriete la tuerca de ajuste. Limpie o reemplace la arandela circular.
Leaks from the hose under the deck.	Hose and spray head connection may be loose.	Tighten the connection between the spray head and hose.
Fuites du tuyau observées sous la plaque.	Le raccord du tuyau à la tête de vaporisation peut être desserré.	Serrez le raccord entre la tête de vaporisation et le tuyau.
Goteo desde la manguera hasta debajo de la cubierta.	La conexión entre el cabezal del rociador y la manguera puede estar floja.	Aprieta la conexión entre el cabezal del rociador y la manguera.
Hose does not retract.	Weight is not installed in the appropriate position.	Reinstall weight (step 8).
Le tuyau ne s'escamote pas.	Le poids n'est pas dans la position Correcte.	Installez à nouveau le poids (étape 8).
La manguera no se retrae.	El peso no está instalado en la posición adecuada.	Reinstalar el peso (paso 8).

Installation / Installation / Instalación

Replacement Parts / Pièces de rechange / Repuestos

No.	Part Name	Part No.
1	Index Button / Capuchon indicateur / Botón indicador	A66G027
2	Metal Handle / Manette en métal / Manija metálicas	A079157*
3	Handle Trim Cap / Garniture de manette / Cubierta de manija	A103214*
4	Locking Nut / Écrou de blocage / Contratuerca	A104338
5	Ceramic Disc Cartridge / Cartouche à disque en céramique / Cartucho de disco cerámico	A507906N
6	Screw / Vis / Tornillo(M5*10L)	A053009
7	Hose Guide (CP, BN) / Guide de boyau / Guía de la manguera	A126048GR
	Hose Guide (ORB) / Guide de boyau / Guía de la manguera	A126048KP
8	Shank Assembly / Assemblage de tige / Ensamblaje de vástago	A081110CP
9	Sprayer / Arroseur / Rociador	A568037N-54*
10	Spray Hose (CP, BN) / Boyau d'arroseur / Manguera del rociador	A515220WGR
	Spray Hose (ORB) / Boyau d'arroseur / Manguera del rociador	A515220WKP
11	Weight / Poids / Pesas	A504713
12	Hose adaptor / Adaptateur de boyau / Adaptador de manguera	A663123N
13	Cover & Putty Plates / Applique et les plaques de mastic / Cubierta y las placas para masilla	A667236*

* please indicate finish for these parts

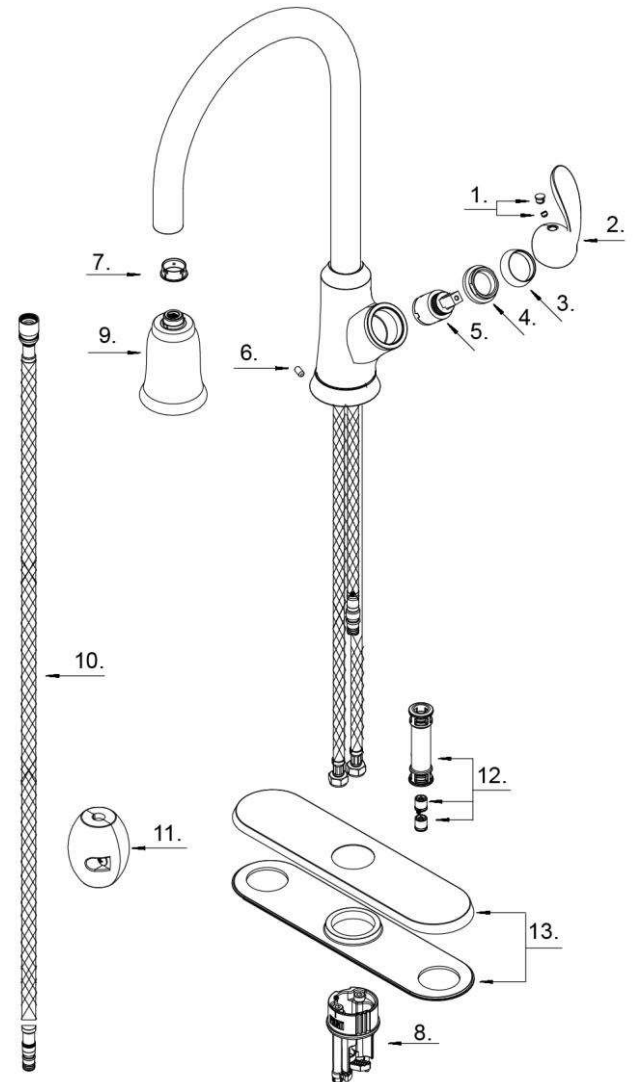

Need Help? Please call our toll-free customer service line at 1-888-328-2383 for additional assistance or service.

Besoin d'aide? Veuillez communiquer avec notre service à la clientèle au numéro gratuit 1-888-328-2383 pour tous renseignements ou services complémentaires.

¿Requiere asistencia? Llame a nuestro Servicio al Cliente, sin costo, al 1-888-328-2383 para asistencia adicional o servicio.

